



Buckets,  
Cutting Edges,  
Thumbs, Rakes,  
Arches, Forks

# SECTION L

## BUCKETS, CUTTING EDGES, THUMBS, RAKES, ARCHES, FORKS

---

	Page
<b>BUCKETS</b>	
FORD BACKHOE	L1
CASE BACKHOE	L1
CAT BACKHOE	L1
CAT EXCAVATOR	L1
EXCAVATOR, CUSTOM	L2
JOHN DEERE BACKHOE	L1
<b>BUCKET TEETH</b>	L3
<b>CUTTING EDGES</b>	
BACKHOE	L5
DOZER	L4-L5
HARDWARE	L5
CUTTING EDGE INFORMATION	L6
<b>FORK ASSEMBLIES</b>	L8
<b>LOG ARCHES &amp; FAIRLEADS</b>	L7
<b>ROOT RAKES</b>	L7
<b>THUMBS</b>	L7

# BACKHOE & EXCAVATOR BUCKETS

STOCK

Part No.	Description	Notes	Wt.	
<b>CASE 480E, 480F, 580, 580B, 580C, 580D, 580SE, 580K, 580SK, 580L, 580SL, 580M, 580SM, 590, 590SL, 590SM, 680, 680B, 680C, 680D, 680E, 680K, 680L</b>				Also Fits Quick Coupler
PV440	13" bucket, with 3 teeth		292	
PV441	18" bucket, with 3 teeth		351	
PV442	24" bucket, with 4 teeth		403	
PV443	36" bucket, with 6 teeth		508	
PV444A	42" Ditch bucket, (smooth edge)		434	
PV444	48" Ditch bucket, (smooth edge)		470	
<b>JOHN DEERE 310, 310A, 310B, 310C, 310D, 310E, 310G, 310J, 310K, 410, 410B, 410C, 410D, 510B, 510C, 510D, 610, 610B, 610C, 610D</b>				Also Fits Quick Coupler
PV450	13" bucket, with 3 teeth		308	
PV451	18" bucket, with 3 teeth		340	
PV452	24" bucket, with 4 teeth		393	
PV453	36" bucket, with 6 teeth		510	
PV454	48" Ditch bucket, (smooth edge)		500	
<b>JOHN DEERE 310SE, 310SG, 310SJ, 310SK, 410E, 410G, 410J, 410K</b>				Also Fits Quick Coupler
PV465	13" bucket, with 3 teeth		310	
PV466	18" bucket, with 3 teeth		349	
PV467	24" bucket, with 4 teeth		397	
PV468	36" bucket, with 6 teeth		509	
PV469	48" Ditch bucket, (smooth edge)		487	
<b>CAT 416, 416B, 416C, 416D, 416E, 420D, 420E, 424D, 426, 426B, 426C, 428, 428C, 428D, 430D, 432D, 436, 436B, 436C, 438C, 438D, 442D</b>				Also fits CAT quick coupler
PV460	13" bucket, with 3 teeth		304	
PV461	18" bucket, with 3 teeth		348	
PV462	24" bucket, with 4 teeth		400	
PV463	36" bucket, with 6 teeth		519	
PV464	48" Ditch bucket, (smooth edge)		461	
<b>FORD 550, 555, 555B, 555C, 555D, 555E, 655, 655B, 655C, 655D, 655E</b>				
PV455	13" bucket, with 3 teeth		370	
PV456	18" bucket, with 3 teeth		418	
PV457	24" bucket, with 4 teeth		483	
PV458	36" bucket, with 6 teeth		600	
PV459	48" Ditch bucket, (smooth edge)		570	
Backhoe bucket specs: 1/4" AR 200 plate sides & bottom, 3/8" wear plates on bottom, 3/4 x 8" H.T. cutting edge, H & L style teeth				
<b>CAT E70B, 307, 307B, 307C, 307SSR</b>				Capacity (cu ft)
PV520	18" bucket, with 4 teeth		424	4.5
PV521	24" bucket, with 4 teeth		488	7.0
PV522	36" bucket, with 5 teeth		591	10.5
PV523	48" Ditch bucket, (smooth edge)		618	12.5
bucket specs: 1/4" AR 200 plate bottom, 3/8" sides, 3/8" wear plates on bottom, no sides, 1x8" H.T. cutting edge, Cat style teeth				
<b>CAT E110B, E120B, 311, 311B, 311C, 312, 312B, 312C</b>				
PV532	18" bucket, with 3 teeth		656	8.0
PV533	24" bucket, with 4 teeth		795	11.0
PV534	42" bucket, with 5 teeth		971	20.0
PV535	60" Ditch bucket, (smooth edge)		940	22.5
bucket specs: 3/8" AR 200 plate bottom & sides, 3/8" wear plates on bottom & sides, AR400 1x10" cutting edge, Cat style teeth ditching bucket has 1/4" bottom plate, no side wear plates				

## EXCAVATOR BUCKETS

Part No.	Description	Notes	Wt.
<b>25 Series Mini Excavator Buckets (Up To 8000 Lbs.)</b>			
PV427	12" bucket, with 3 teeth	Komatsu PC25, PC30	1.5
PV428	18" bucket, with 4 teeth	Yanmar Vio27, B37, Vio 35, YB271	2.5
PV429	24" bucket, with 4 teeth		3.5
PV430	36" bucket, (Ditch) smooth edge		5.5
Bucket specs: 1/4" AR200 plate sides & bottom, 1/4" AR200 wear plates on bottom, 3/4 x 6" H.T. cutting edge, H & L style teeth			
<b>40 Series Mini Excavator Buckets (8000 To 12000 Lbs.)</b>			
PV445	12" bucket, with 3 teeth	Komatsu PC40, PC45, PC50	2.0
PV446	18" bucket, with 4 teeth	Hitachi EX50	3.5
PV447	24" bucket, with 4 teeth	Yanmar Vio40, 50, B50	4.5
PV448	36" bucket, (Ditch) smooth edge		7.0
Bucket specs: 1/4" AR200 plate sides & bottom, 3/8" AR200 wear plates on bottom, 3/4 x 6" H.T. cutting edge, H & L style teeth			
<b>70 Series Excavator Buckets (14000 To 18000 Lbs.)</b>			
PV528	18" bucket, with 4 teeth	JD 70, 70D, 190E, 80, 80C	4.5
PV529	24" bucket, with 4 teeth	Hitachi EX60	7.0
PV530	36" bucket, with 5 teeth	Komatsu PC60, PC70	10.5
PV531	48" bucket (Ditch) smooth edge	Yanmar Vio70, 75	12.5
Bucket specs: 1/4" AR200 plate bottom, 3/8" sides, 3/8" AR200 wear plates on bottom, 1 x 8" H.T. cutting edge, Cat style teeth			
<b>120 Series Excavator Buckets (22000 To 30000 Lbs.)</b>			
PV536	18" bucket, with 3 teeth	JD 110, 120, 490D, 490E, 495D	9.0
PV537	24" bucket, with 4 teeth	Hitachi EX100, 120, 135	12.0
PV538	42" bucket, with 6 teeth (1175)	Komatsu PC100, PC120	21.0
PV539	60" bucket (Ditch) smooth edge	Cat 312, 312B, 312C	
Specs: 3/8" AR200 plate bottom & sides, 3/8" AR200 wear plates on bottom & sides, 1 x 10 AR400 cutting edge, Cat style teeth ditching bucket has 1/4" bottom plate, no side wear plates			
<b>160 Series Excavator Buckets (30000 To 40000 Lbs.)</b>			
PV540	24" bucket, with 3 teeth	JD 160LC, 160CLC, 690, 690A	15.0
PV541	36" bucket, with 4 teeth	Hitachi EX150, 160	23.0
PV542	48" bucket, with 6 teeth	Komatsu PC150, 160	30.0
PV543	72" bucket (Ditch) smooth edge	Cat 315, 315B, 315C	35.0
3/8" AR200 plate bottom 1/2" AR200 sides 3/8" AR200 wear plates on bottom & sides 1 1/4 x 12" AR400 cut edge Cat style teeth			
<b>200 Series Excavator Buckets (40000 To 50000 Lbs.)</b>			
PV544	24" bucket, with 3 teeth (1410)	JD 200LC, 220CLC, 690B, 690D, 690E	19.0
PV545	36" bucket, with 4 teeth	Hitachi EX200	28.0
PV546	48" bucket, with 6 teeth	Komatsu PC200	37.0
PV547	72" bucket (Ditch) smooth edge	Cat 318C, 320, 320B, 320C, 320L	46.0
3/8" AR200 plate bottom 1/2" AR200 sides 3/8" AR200 wear plates on bottom & sides 1 1/4 x 12" AR400 cut edge Cat style teeth			
Buckets on this page are in stock without ears. Allow 5 days to manufacture ears and weld to bucket.			

## BUCKET TEETH & ADAPTERS

Part No.	Description	Notes	Wt.
<b>H&amp;L Style</b>			
230010	Adapter, Weld On	3/4" cutting edge	3.4
230	Tooth		3.5
23P	Pin		0.1
<b>ESCO Style</b>			
18TL	Tilt Tooth		3.1
18PN	Pin		0.1
18LK	Lock		0.1
25S	Sharp Tooth		5.1
25/30PN	Pin		0.2
25/30LK	Lock		0.1
30S	Sharp Tooth		7
35S	Sharp Tooth		9.1
35PN	Pin		0.1
35/40LK	Lock		0.1
<b>CAT Style</b>			
8J7525	Adapter, Weld On	3/4" cutting edge	3.1
1U3202	Long Tooth		3
8E6208	Slotted Pin		0.1
8E6209	Retainer		0.1
6Y3224	Adapter, Weld On	1" cutting edge, 70 Series	6.6
6Y3222	Long Tooth	70 Series	4.2
6Y3228	Slotted Pin		0.1
3G9609	Retainer		0.1
6Y3254	Adapter, Weld On	1" cutting edge, 120 Series	9
1U3252	Long Tooth	120 Series	6.5
9J2258	Slotted Pin		0.2
3G9609	Retainer		0.1
3G6304	Adapter, Weld On	1 1/4" cutting edge, 160, 200 Series	21
1U3302	Long Tooth	160, 200 Standard Size	10
9J2308	Slotted Pin		0.2
3G9609	Retainer		0.1
3G8354	Adapter, Weld On	1 1/2" cutting edge, 200 heavy duty series	21
1U3352	Long Tooth	200 heavy duty series	13
8E6358	Slotted Pin		0.2
3G9549	Retainer		0.1

## DOZER CUTTING EDGES

CASE DOZERS	L/H	CENTER	R/H
350B	R57841	R24492	R57841
450, 450B, 450C	R57841	R57842	R57841
450C, 550, 550G LGP	R57841	R57843	R57841
550, 550G	R57841	R57844	R57841
550H	305440A1	311729A1	305440A1
550H LGP	305440A1	N/A	305440A1
650	R42470	R44600	R42470
850B, 850C, 850D, 850E	R42470	R44600	R42470
650G, 650H, 650K, 750H, 750K	R42490	(2) 115631A1	R42490
850G, 850H, 850K	R42490	(2) 115631A1	R42490
1150B	N/A	R41350	N/A
1150E	R42470	(3) R44885	R42470
1150G, 1150H	R42490	N/A	R42490

JOHN DEERE DOZERS	L/H	CENTER	R/H
350	U11708	U11707	U11708
400G	T31148	N/A	T31148
450C, 550	T31148	U16748	T31148
450E LT, 550B LT	T31148	T32742	T31148
450G, 450H, 450J	T162841	T120979	T162841
550G, 550H, 550J	T162841	T120980	T162841
650G, 650H, 650J	T162841	T120980	T162841
650G, 650H, 650J	T162841	T120981	T162841
650G, 650H, 650J	T162841	T140560	T162841
700H	T162841	T175278	T162841

CAT DOZERS	L/H	CENTER	R/H
D3, D3B	4T6229	(2) 4T6230	4T6229
D3C, D3G	6Y5840	(2) 4T6230	6Y5839
D4C, D4G	6Y5840	(2) 6Y5842	6Y5839
D5C, D5G	6Y5840	(2) 6Y5842	6Y5839
D4D, D4E, D5	5J6924	N/A	5J6923
D4D, D4E, D5 HEAVY DUTY	5J6924HD	N/A	5J6923HD
D4H	3G4285	3G9306	3G4285
D5H	3G4285	3G4282	3G4285
D4H, D5H HEAVY DUTY	4T5407	N/A	4T5408
D6H	9W8875	9W1878	9W8874
D7E, D7F, D7H, D8	5J6927	N/A	5J6928

**DOZER & BACKHOE CUTTING EDGES**
**WELD-ON EDGES**

DRESSER DOZERS	L/H	CENTER	R/H
TD7	620529C1	620563C1	620530C1
TD7G	620529C1	620563C1	620530C1
TD8	620691C1	620690C1	620692C1
TD8G	620691C1	620690C1	620692C1

KOMATSU DOZERS	L/H	CENTER	R/H
D31	11G-71-31170	(2) 12F-70-31251	11G-71-31170
D37	11G-71-31170	12F-70-31251 & 12F-70-31261	11G-71-31170

CASE BACKHOES	Part No.	Length
580SK	D145681	82"
580L, 580SL	112946A1	82"
580M, 580SM	112946A1	82"

CAT BACKHOES	Part No.	Length
416B	(2) 9W8215	44 1/2"

JOHN DEERE BACKHOES	Part No.	Length
310D, 310SE, 310SG	T84194	92 3/8"
310D, 310SE, 310SG	T150517	86"

CUTTING EDGE BOLTS		CUTTING EDGE NUTS	
4F3649	Bolt 1/2" x 2"	1F7958	Nut 1/2"
4F3654	Bolt 5/8" x 2"	4K0367	Nut 5/8"
4F3656	Bolt 5/8" x 2 1/2"	2J3506	Nut 3/4"
5J4773	Bolt 3/4" x 2 1/2"		
5J4771	Bolt 3/4" x 3"		

WELD-ON CUTTING EDGES			Weight (lbs. / ft.)
11318	3/4" x 4"	Flat Single Bevel	8.33
11139	3/4" x 6"	Flat Single Bevel	12
10549	3/4" x 8"	Flat Single Bevel	16.8
10732	1" x 8"	Flat Single Bevel	24.38

## CUTTING EDGE INFORMATION

Part No.	No. of Holes	Hole Size	Th x W x L	Weight
112946A1	10	3/4	3/4 x 8 x 82	129
115631A1	6	3/4	3/4 x 8 x 34 1/8	53
11G-71-31170	4	5/8	5/8 x 6 x 15	14
12F-70-31251	5	5/8	5/8 x 6 x 29 7/8	28
12F-70-31261	6	5/8	5/8 x 6 x 35 7/8	34
305440A1	3	3/4	3/4 x 8 x 18	28
311729A1	10	3/4	3/4 x 8 x 59 1/4	92
3G4282	7	3/4	3/4 x 8 x 45 1/4	70
3G4285	4	3/4	3/4 x 8 x 16 3/4	26
3G9306	6	3/4	5/8 x 8 x 34 3/4	44
4T5407	4	3/4	1" Th (Hot Cup)	51
4T5408	4	3/4	1" Th (Hot Cup)	51
4T6229	3	5/8	3/4 x 6 x 13	15
4T6230	6	5/8	5/8 x 6 x 34 1/4	33
5J6923	6	5/8	3/4 x 8 x 13 1/8	20
5J6923HD	6	5/8	1 x 8 x 13 1/8	27
5J6924	6	5/8	3/4 x 8 x 13 1/8	20
5J6924HD	6	5/8	1 x 8 x 13 1/8	27
5J6927	7	3/4	1 x 10 x 17 3/4	44
5J6928	7	3/4	1 x 10 x 17 3/4	44
620529C1	3	3/4	5/8 x 6 x 14 7/8	14
620530C1	3	3/4	5/8 x 6 x 14 7/8	14
620563C1	5	3/4	5/8 x 6 x 29 7/8	28
620690C1	5	3/4	3/4 x 6 x 29 3/4	34
620691C1	3	3/4	3/4 x 6 x 17 1/4	19
620692C1	3	3/4	3/4 x 6 x 17 1/4	19
6Y5839	3	5/8	5/8 x 6 x 13 7/8	12
6Y5840	3	5/8	5/8 x 6 x 13 7/8	12
6Y5842	8	5/8	5/8 x 6 x 49 7/8	48
9W1878	8	3/4	3/4 x 10 x 48 1/4	91
9W8215	4	5/8	3/4 x 8 x 44 1/2	70
9W8874	6	3/4	1 x 10 x 18 3/8	44
9W8875	6	3/4	1 x 10 x 18 3/8	44
D145681	10	3/4	3/4 x 8 x 82	126
R24492	9	1/2	1/2 x 6 x 63 7/8	48
R41350	24	5/8	5/8 x 6 x 95 7/8	90
R42470	3	5/8	5/8 x 6 x 13 1/2	13
R42490	5	3/4	3/4 x 8 x 17 1/2	27
R44600	13	5/8	5/8 x 6 x 74 3/4	71
R44885	6	5/8	5/8 x 6 x 33	32
R57841	3	1/2	5/8 x 6 x 12	11
R57842	16	1/2	5/8 x 6 x 63 3/4	61
R57843	20	1/2	5/8 x 6 x 79 7/8	76
R57844	18	1/2	5/8 x 6 x 71 3/4	69
T120979	7	3/4	3/4 x 8 x 70 5/8	110
T120980	7	3/4	3/4 x 8 x 78 5/8	124
T120981	9	3/4	3/4 x 8 x 94 5/8	148
T140560	9	3/4	3/4 x 8 x 88 5/8	133
T150517	7	5/8	3/4 x 8 x 86	135
T162841	3	3/4	3/4 x 8 x 13	20
T175278	9	3/4	3/4 x 8 x 93 5/8	146
T31148	3	3/4	3/4 x 6 x 12	14
T32742	7	3/4	5/8 x 6 x 71 7/8	69
T84194	8	5/8	3/4 x 8 x 92 3/8	146
U11707	5	5/8	1/2 x 6 x 55 7/8	42
U11708	3	5/8	5/8 x 6 x 12	11
U16748	7	3/4	5/8 x 6 x 65 7/8	63



## THUMBS

Part No.	Description	Notes	Wt.
<b>MINI EXCAVATORS &amp; BACKHOES (8,000 to 15,000 lb. Excavator) 12" x 36"</b>			
PV4200	Manual Thumb	3 tines	127
<b>70 SERIES THUMBS (15,000 to 22,000 lb. Excavator) 12" x 40"</b>			
PV4300	Manual Thumb	3 tines	285
PV4301	Hydraulic Thumb	3 tines	308
<b>120 SERIES THUMBS (24,000 to 36,000 lb. Excavator) 18" x 50"</b>			
PV4500	Manual Thumb	4 tines	600
PV4501	Hydraulic Thumb	4 tines	672
<b>200 SERIES THUMBS (40,000 to 46,000 lb. Excavator) 24" x 58"</b>			
PV4600	Manual Thumb	4 tines	1088
PV4601	Hydraulic Thumb	4 tines	1185

## ROOT RAKES

ROOT RAKES			All Root Rakes Include 2 Mounting Brackets & 2 Pins	
PV490	7' Wide	8 Tines		1020
PV491	8' Wide	9 Tines		1350
PV491A	8' Wide-Tall Style	9 Tines		1492
PV492	9' Wide	10 Tines		1611
PV493	10' Wide	11 Tines		2165
				<b>MOUNTING BRACKET</b>

## LOG ARCHES & FAIRLEADS

<b>JOHN DEERE 350, 350B, 350C, 350D</b>			
PV498A	Log Arch	Special Order Allow One Week	450
AT15492	Winch Fairleads		190
<b>JOHN DEERE 450-BCDE, 455D-E, 550-AB, 555-AB</b>			
PV498	Log Arch		473
AT15492	Winch Fairleads		190
<b>JOHN DEERE 450G, 455G, 550G, 555G, 650G, 450H, 550H, 650H, 450J, 550J, 650J</b>			
PV499	Winch Fairleads	For 4000 series winch	291
<b>JOHN DEERE 450G, 550G, 650G, 450H</b>			
PV4400	Log Arch w/ Fairleads	For 4000 series winch	680
<b>JOHN DEERE 550H, 650H, 550J, 650J</b>			
PV4401	Log Arch w/ Fairleads	For 4000 series winch	680
<b>CASE 450, 450B, 450C, 455C, 850, 850B, 850C, 850D, 850E, 855C, 850D (For Model 19 Winch)</b>			
PV494	Winch Fairleads		261
<b>CASE 650, 850B, 850C, 850D, 850E, 855C, 855D</b>			
PV496	Log Arch	650, 850B, 850C, 850D, 850E, 855C, 855D	554
<b>CARCO 30</b>			
PV499A	Winch Fairleads	Carco 30	233
PV497	Arch Head	Generic arch head to be shop fit by customer.	240

\*Warranty is void if installed on machine over 15,000 lbs.

## FORK ASSEMBLIES

Ref.	Part No.	Description	Notes	Fork Size
<b>BLANK FORKS (Sold as a set of 2 only)</b>				
1	P2.063648	Forks		2.0 x 6 x 36 x 48
2	P2.563648	Forks		2.5 x 6 x 36 x 48
3	P2.563660	Forks		2.5 x 6 x 36 x 60
4	P2.563672	Forks		2.5 x 6 x 36 x 72
5	P2.563684	Forks		2.5 x 6 x 36 x 84

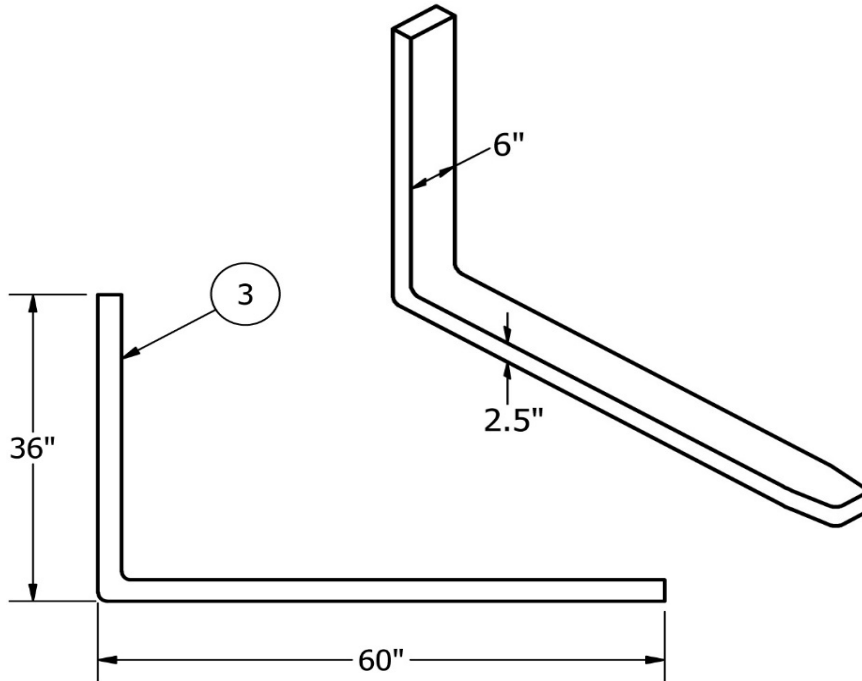

### CUSTOM FORK ASSEMBLIES

CUSTOM FORK ASSEMBLIES ARE AVAILABLE FOR ALL LOADERS UP TO 40,000 LBS.

ALL FORK ASSEMBLIES HAVE A 2 WEEK LEAD TIME, PLEASE CALL FOR A QUOTE

